

# Vibrating Rod Point Switch - VRS

Based on piezo driven vibration technology for level detection of granules and powders in small silos & bins. A round shaped vibrating rod prevents typical bridging problems faced in vibrating fork resulting in false alarm.

## Salient Features:

- Compact & easy to install
- No moving parts. Minimum maintenance
- Unique self-cleaning probe due to vibration
- Fail safe high & low selection

## Construction & Operation:

It consists of sensing rod with integral electronics housed in an enclosure at its top. On supplying power, sensing rod is set into the mechanical vibrations at its resonance frequency, driven by piezo crystal. However vibrations get damped when rod gets covered with material. This is sensed by electronics to provide change over contacts which can be used for alarm indication/control or connected to PLC/DCS

## Specifications:

### Sensing probe

Mounting	: Top/Side
Vibrating Rod MOC	: SS304
Pr. Connection MOC	: SS304 (Screwed), CS /SS304 (Flange)
Proces Connection	: 1-1/2" BSP (M) Screwed or 1-1/2"ASME 150# Flange
Insertion Length	: 250 mm to 3000 mm
Resonance Freq.	: 300 Hz
Particle/ Grain Size	: upto 20 mm
Min. Bulk Density	: >0.5 g/cm <sup>3</sup>
Max Temperature	: 150 °C
Test Pressure	: -1 to 10 bar

### Electronics (Integral)

Enclosure	: Cast Al. IP66 protection
Cable Gland	: PG13.5 x 2 nos, Polyamide
Supply	: 65 to 265 V AC or 24 VDC ±10%
Output	: Potential free relay contacts 5A, 230VAC, 2 x SPDT
Power Consumption	: 1.8VA (AC), 1.5W (DC)
LED Indication	: Green (Normal) & Red (Alarm)
Fail Safe Selection	: High (FSH), Low (FSL) field selectable
Switching Delay (Optional)	: 2 to 20 second adjustable probe free to probe covered
Amb. Temperature	: 0 to 60 °C

## Applications:

Milk/Chocolate/coffee powder, flour,spices,cofee bean, tea, salt, sugar, grains, peanuts, sweets & candy, animal/pet food, cellulose/ polystyrene/ glass fine powder, cement, dry soot, soda ash, coal ash, foundary sand, gravel, granular plastics, plastic pellets, wood shavings and chalk.

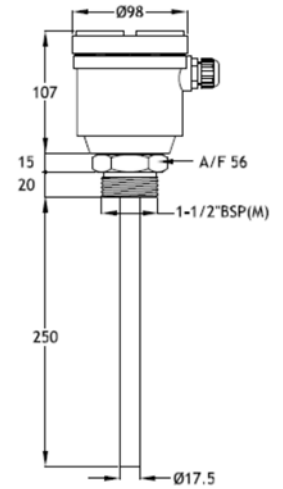

## Installation:

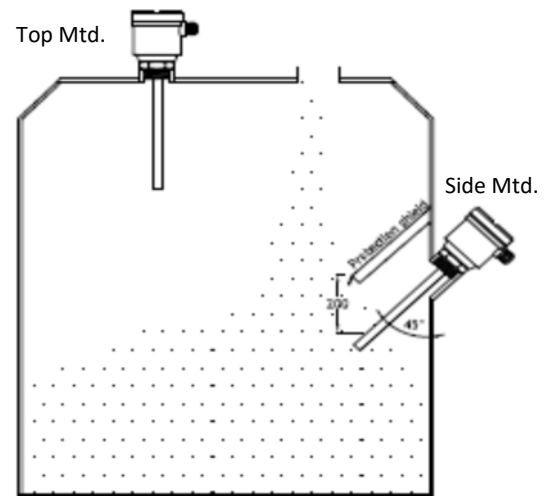

Protection shield is recommended to protect rod against material directly falling on rod at inlet or loading due to material

## Model Identification:

### Process Conn. MOC x Type

SS304 x 1-1/2" BSP (M) Screwed	-----1
SS304 x 1-1/2" ASME Flange 150 #	-----2
CS x 1-1/2" ASME Flange 150 #	-----3
Others	-----0

### Power Supply

65 to 265 V AC	-----1
24 V DC	-----2

### Switching Delay

Not Provided	-----W
Provided	-----P



All dimensions in mm except specified