

Please read the manual to ensure proper installation and maintenance of gauge. To get best intrinsic value of every Techtrol product it should be used within its specified limits. Besides, carry out periodic preventive maintenance to extend the working life of your instrument.

Pre-Installation Check

- ☑ Ensure that supplied gauge is in accordance to required specification.
- ☑ Visually examine glass tube for any cracks or damages.
- ☑ If the gauge is all right, proceed for installation.

Installation (Fig. 1)

1. Select suitable location on tank where vibrations are minimum.
2. Ensure tank thread fittings match with gauge connections.
3. The gauge is side mounted to tank, ensuring it is mounted in plumb.
4. CC distance of tank should correspond to CC dist of gauge.
5. Apply suitable thread sealant between the threads before tightening thread fittings to ensure zero leakage.

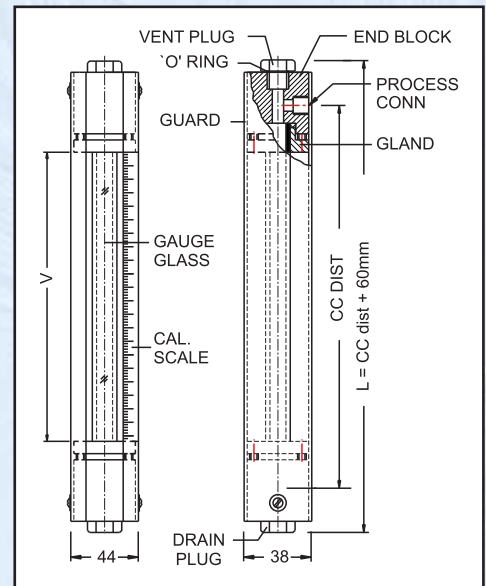

Maintenance

1. Periodically examine gauge glass for cracks/damages. Replace gauge glass if found damaged.
2. Gauge glass tube can be cleaned by opening vent & drain plugs and pouring warm water through vent opening.
3. Periodically examine gauge for any leakages thru tank fittings / drain plug. Tighten fasteners/plug adequately to stop leakage.
4. In case of leakage through gauge glass, replace gland packings.

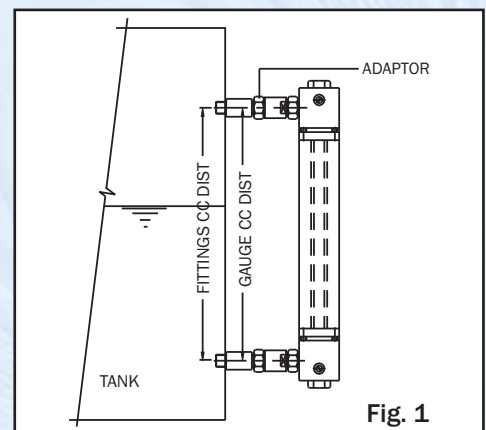

Replacement of glass tube / gland packing (Fig. 2)

1. Empty the tank and detach gauge from tank.
2. Remove drain, vent, guard screws and gland bolts.
3. Remove gauge glass & gland packings and clean the gauge parts for any dirt or deposits.
4. Discard used gland packings, every time gauge glass is replaced, use fresh gland packings in their place.
5. Place gland packings on both end blocks.
6. Insert gland over the gauge from both sides and fit the gauge between the end blocks and tighten gland bolts adequately.
7. Ensure that gauge glass is held in plumb.
8. Screw side guards to end blocks.
9. The gauge is now ready for use.

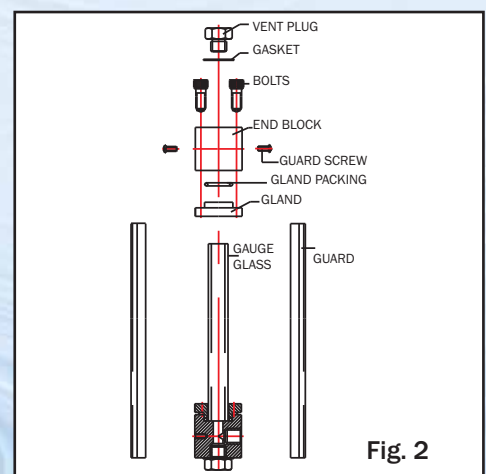

Caution

- ☑ Do not use gauge beyond the specified limits of temp & pressure.
- ☑ Replace damaged gauge glass immediately.
- ☑ Do not reuse gland packings.
- ☑ Do not overtight glands as they may damage the glass.

Pune Techtrol Pvt Ltd

Regd. Off. : S-18, MIDC, Bhosari, Pune - 411026. India

Works : J-52/7, MIDC, Bhosari, Pune - 411026. India

Tel. : +91-20-66342900, 27121052

Fax : +91-20-66342998

E-mail : ho@punetechtrol.com

Web : www.punetechtrol.com

Custom built specs./options available on demand.



We reserve the right to modify design and specifications without prior notice.

Area Representative / Distributor :