

LEOMI 587 DATA SHEET

Actual Mass/Volume Flow Meter

Design	Insertion probe with separate electronic converter (remote control)
Function Principle	Heat dissipation technique (calorimetric), primary signal mass flow proportional, independent of pressure and temperature
Sensor Details	2 X Pt-100 RTD with ceramic wire-wound sensor element encapsulated in SS-316Ti (1.4571) tube (4-wire Technique); Diameter:12mm, 20 mm, 25mm (Optional) Length: 250mm, 500mm, 1000 mm (Other upon request)
Sensor Material	SS-316Ti (DIN1.4571)/ Hastelloy C276, HALAR [®] & PFA Coating for corrosive gases (optional) (Others consult factory)
Fluids	Air & Gases
Flow Range	0.6 – 65 Nm/s (std), 0.6 -150 Nm/s (optional) (with extrapolation above 65 Nm/s) (Reference as per DIN 1343; 0°C/1.01325 bar(a), 0%RH) (other upon request)
Turndown ratio	100 : 1 or better
Stored Calibration Curve	60 points, firmware internal Spline interpolation
Accuracy (%)*	±1.5% reading (-40°C-100°C); ±2.0% reading (0°C -200°C/ 300°C/ 400°C) for >=5m/s; +/- 0.1m/s or better below 5m/s velocity at reference calibration conditions upto 75 m/s (* Better accuracy possible with additional charges, please consult factory)
Repeatability (%)	±0.5% of reading
Response time t90	<3 secs
Warming Up Time	5min after switching on
Operating temperature	-40°C to +100°C, 0 - 200°C; 0 -300°C; 0 - 400°C
Operating pressure	16bar(g) Max. PN16 (Higher upon request)
Ambient temperature	-20°C to +60°C
Installation Position	Unrestricted, apart from bottom of pipe to avoid any moisture or particles
Steadying Distance	15 D upstream,5D downstream (where D=Inner diameter of pipe) (Minimum steadying distance depends upon the application. Longer steadying distances have to be considered, if double elbows or partly closed valves have been installed in front of the unit) (Note: Suitable flow straightener is recommended for short steadying distance, Refer installation and operating instructions manual for details)
Process connection	½" or ¾" NPT (M) Compression Ferrule; ½" or ¾" NPT (F) Full port ball-valve (optional) (Other upon request)

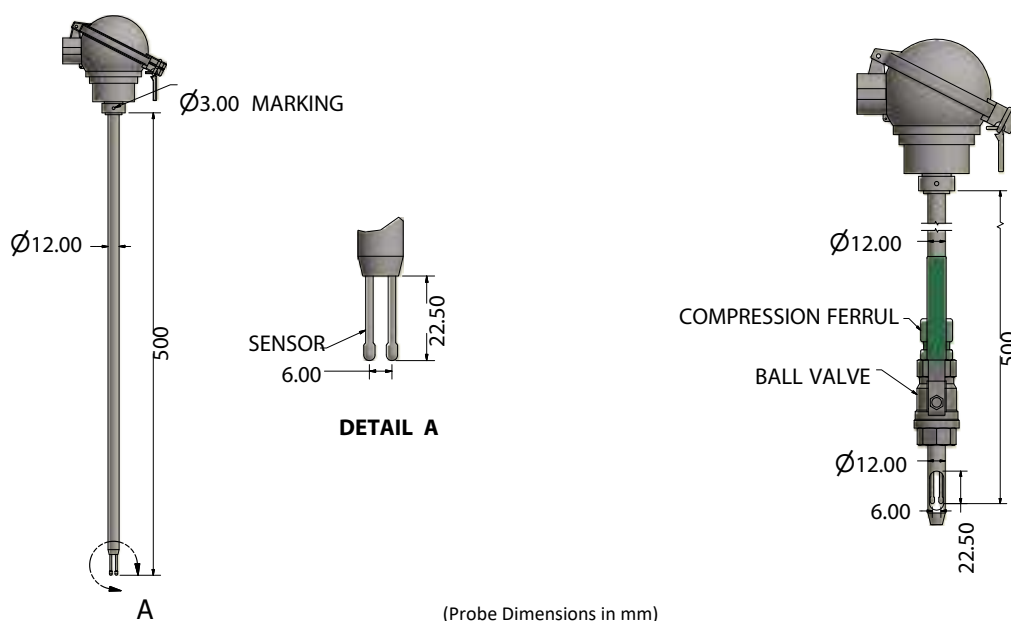

<i>Remote Signal Transmitter</i>	Microprocessor based, complete and automatically compensation of temperature conditioned signal drifting. Digital conductivity compensated adjustment of heater over temperature
<i>Function</i>	Operating Volume/Mass Flow controller with multiple input configuration with inbuilt data logging functions& application formula with customized software ¹ .
<i>Power Supply</i>	24VDC (18 - 36VDC) OR 100 – 265 VAC@50Hz
<i>Power Consumption</i>	< 10 watts
<i>Display</i>	16 X 4 LCD for user selectable parameters (actual volume/mass flow, temperature, pressure, humidity, power etc)
<i>Display Indication Values</i>	Mass flow and totalizer, volume flow and totalizer, velocity, temperature (user selectable)
<i>Measuring Unit:</i>	Mass Flowrate (Kg/Hr) & Totalizer (Kg) Volume flowrate (m3/Hr or CFM) & Totalizer (m3 or CF) & Process Temperature (°C)
<i>Signal Input</i>	1xPt100 heater, four-wire technique, 1xPt100 reference, four-wire technique
<i>Signal Output</i>	0/4-20 mA DC (Isolated @600Ω) OR 0 -10VDC flowrate proportional; 1 NO / NC Relay contact @ 250VAC / 6A. programmable for Temperature OR Flowrate, Opto-coupler impulse output, other data available on request
<i>Ingress Protection</i>	Sensor probe IP67; Signal Transmitter: IP65(std)/ IP66(optional) (Other upon request) as per IS-60947/IEC-60529
<i>Enclosure MOC</i>	ABS Plastic 150mm(W) x 200mm(L) x 79mm(H) (standard); Aluminum Diecast 160mm(W) x 260mm(L) x 91(H) (other upon request)
<i>Certifications</i>	EMC/EMI compliant as per IEC 61000 standards
<i>Connecting Cable (Electronic Converter to Probe)</i>	FEP/PTFE (optional) Insulated, Length 5m (standard), 10m (optional) (Other upon request)
<i>Electrical Connections</i>	Plugged spring-cage connection for all inputs and outputs (max.1,0mm ²)
<i>Analogue I/P:</i>	Upto 4 channel (4-20mADC or 0-5VDC or 0-10VDC) input user configurable for (pressure, temperature, humidity, power etc) ²
<i>Analogue O/P:</i>	1 No. (0/4-20mADC OR 0-5VDC) output for re-transmission programmable for actual volume or mass flow rate.
<i>Relay O/P:</i>	2 Nos. 1C/NO contact for Auto-purging or alarm Relay
<i>In-built Storage:</i>	USB port for data storage of all readings in USB.2.0 pen drive
<i>Communication Interface:</i>	RS485 Modbus RTU protocol with LEOMI 587.1.0.0 configuration software ³
<i>Data protection:</i>	nvSRAM (non-volatile storage)
<i>Terminal connector:</i>	Spring-cage connection (pluggable) for all inputs and outputs (max.1,0mm ²)
<i>Software Pack:</i>	LEOMI 587.1.0.0 configuration software for add-on board programming.
<i>Accessories:</i>	RS-485 Modbus RTU to USB serial interface converter (optional)

- NOTE:** 1 - LEOMI provides customized software based on customer application study.
 2 - Input is selectable as per applications and can be customized based on application study.
 3 - Main board parameter programming via terminal software Leomi 586.1.0.0.

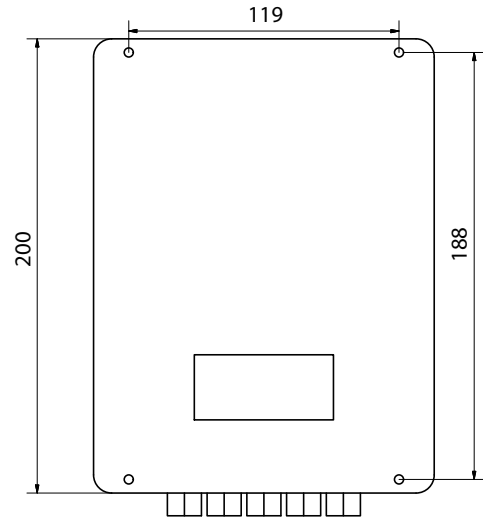
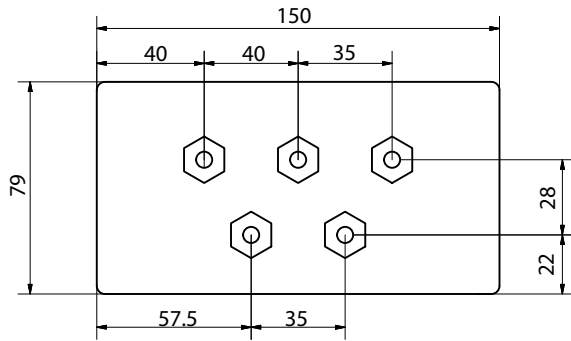

(Enclosure Dimensions in mm)

Table: Pipe dimension & flowrates as per DIN 1343 0°C/1.01325 bar(a), 0% RH)

mm	15-25	32	40	50	65	80	100	200	300	3000
Nm ³ /h	100	170	260	410	700	1000	1700	6800	15200	1500000

Note: Technical specifications and dimensions subject to change due to continuous research and development.

LEOMI INSTRUMENTS PVT. LTD.

E-17/5, Electronic GIDC, Sector-26, Gandhinagar-382027, Gujarat, INDIA.

+91 79 23287899, +91 90547 50586 sales@leomi.in www.leomi.in

AutomationCommunity.com